

12-Person Jury

FILED
1/19/2023 11:49 AM
IRIS Y. MARTINEZ
CIRCUIT CLERK
COOK COUNTY, IL
2023CH00537
Calendar, 16
21109123

**IN THE CIRCUIT COURT OF COOK COUNTY, ILLINOIS
COUNTY DEPARTMENT, CHANCERY DIVISION**

**THE STATE OF ILLINOIS, *ex rel.*,
[SUPPRESSED],**

Plaintiff-Relator,

v.

[SUPPRESSED],

Defendants.

Case No. **2023CH00537**

DEMAND FOR JURY TRIAL

Filed In Camera and Under Seal
Pursuant to 740 ILCS 92/15(b)

CIVIL COVER SHEET

COMPLAINT

FILED DATE: 1/19/2023 11:49 AM 2023CH00537

Chancery Division Civil Cover Sheet
General Chancery Section

(12/01/20) CCCH 0623

IN THE CIRCUIT COURT OF COOK COUNTY, ILLINOIS
COUNTY DEPARTMENT, CHANCERY DIVISION

The State of Illinois, ex rel., [SUPRESSED],
Plaintiff
v.
[SUPRESSED]
Defendant

Case No: 2023CH00537

CHANCERY DIVISION CIVIL COVER SHEET
GENERAL CHANCERY SECTION

A Chancery Division Civil Cover Sheet - General Chancery Section shall be filed with the initial complaint in all actions filed in the General Chancery Section of Chancery Division. The information contained herein is for administrative purposes only. Please check the box in front of the appropriate category which best characterizes your action being filed.

Only one (1) case type may be checked with this cover sheet.

- 0005 Administrative Review
- 0001 Class Action
- 0002 Declaratory Judgment
- 0004 Injunction
- 0007 General Chancery
- 0010 Accounting
- 0011 Arbitration
- 0012 Certiorari
- 0013 Dissolution of Corporation
- 0014 Dissolution of Partnership
- 0015 Equitable Lien
- 0016 Interpleader
- 0017 Mandamus
- 0018 Ne Exeat
- 0019 Partition
- 0020 Quiet Title
- 0021 Quo Warranto
- 0022 Redemption Rights
- 0023 Reformation of a Contract
- 0024 Rescission of a Contract
- 0025 Specific Performance
- 0026 Trust Construction
- 0050 Internet Take Down Action (Compromising Images)
- Other (specify) _____

Atty. No.: 46703 Pro Se 99500

Atty Name: David J. Chizewer, Roger A. Lewis

Atty. for: Plaintiff-Relator

Address: Goldberg Kohn Ltd., 55 E. Monroe St.

City: Chicago State: IL

Zip: 60603

Telephone: 312-201-4000

Primary Email: roger.lewis@goldbergkohn.com

Pro Se Only: I have read and agree to the terms of the Clerk's Clerk's Office Electronic Notice Policy and choose to opt in to electronic notice from the Clerk's office for this case at this email address:

Email: _____

IN THE CIRCUIT COURT OF COOK COUNTY, ILLINOIS
COUNTY DEPARTMENT, CHANCERY DIVISION

THE STATE OF ILLINOIS, *ex rel.*,
[SUPPRESSED],

Plaintiff-Relator,

v.

[SUPPRESSED],

Defendants.

Case No. 2023CH00537

DEMAND FOR JURY TRIAL

Filed In Camera and Under Seal
Pursuant to 740 ILCS 92/15(b)

IN THE CIRCUIT COURT OF COOK COUNTY, ILLINOIS
COUNTY DEPARTMENT, CHANCERY DIVISION

THE STATE OF ILLINOIS, *ex rel.*, BRIAN
WILLIAMS,

Plaintiff-Relator,

v.

SAFELITE GROUP, INC., SAFELITE
FULFILLMENT, INC., d/b/a SAFELITE
AUTOGLASS, and SAFELITE SOLUTIONS
LLC,

Defendants.

Case No. 2023CH00537

DEMAND FOR JURY TRIAL

Filed In Camera and Under Seal
Pursuant to 740 ILCS 92/15(b)

COMPLAINT

Plaintiff-Relator BRIAN WILLIAMS (“Williams” or “Relator”), and THE STATE OF ILLINOIS, *ex rel.* WILLIAMS (“State of Illinois”), state and allege as follows:

INTRODUCTION

1. This is an action by Williams to recover damages and civil penalties on behalf of the People of the State of Illinois, arising from an insurance fraud scheme planned and carried out by Defendants SAFELITE GROUP, INC. (“Safelite Group”), SAFELITE FULFILLMENT, INC., doing business under its tradename SAFELITE AUTOGLASS (“Safelite AutoGlass”), and SAFELITE SOLUTIONS LLC (“Safelite Solutions,” and with Safelite Group and Safelite AutoGlass, “Safelite” or “Defendants”) involving the production of false and misleading bills to insurance companies concerning a replacement part Safelite uses to repair automobile glass, as well as for services that Defendants only provided for a small number of customers. As a direct

result of Defendants' conduct, false and fraudulent claims have been made against consumers and insurance policies issued by numerous insurance companies, including but not limited to GEICO, Allstate Insurance Company, Nationwide Mutual Insurance Company, The Travelers Companies, Inc., and Progressive Corporation. As a direct result of the Defendants' conduct, insurance companies and their policyholders have incurred substantial financial losses. Williams, therefore, brings this action on behalf of the People of the State of Illinois to recover monetary civil penalties and assessments, and to enjoin, deter, and/or prevent Defendants from engaging in such conduct in the future.

2. This Complaint for damages arises from an investigation Williams initiated in the summer of 2019. As a result of his investigation, Williams uncovered an insurance fraud scheme that originated from, and was planned and developed, by Defendants through their agents and carried out by Defendants. In substance, the scheme involves the invoicing of automobile repair parts that are misleading, false, and fraudulent, and knowing that such documentation would be submitted to the insurance companies in support of claims made under the policies of insurance. Indeed, although Defendants exuded the image that they were using the best parts available in the industry, Defendants were instead allowing employees to use parts of lesser quality while billing insurance companies at market rates. The conduct of Defendants was undertaken with the intent to deceive insurance carriers for financial gain and with a conscious disregard of the rights of the insurance carriers and customers.

3. This Complaint also alleges false claims arising from a sanitization service supposedly provided by Safelite and concocted in response to the COVID-19 pandemic, but, which for the most part, never actually happened. Like its repair parts scheme, Defendants undertook this

arrangement with the intent to deceive insurance carriers for financial gain and with a conscious disregard of the rights of the insurance carriers and customers.

4. Together, these schemes resulted in tens—if not hundreds—of millions of dollars in overcharges to private insurers for claims filed in Illinois alone; overcharges which have undoubtedly been passed on to all Illinois citizens through increased premiums.

5. Williams is the original source for the information contained in this Complaint as it relates to the fraudulent claims.

6. Insurance companies, the motoring public, and the State of Illinois were and are the direct victims of the illegal and fraudulent scheme conducted by Defendants.

7. Defendants have knowingly engaged in illegal and fraudulent practices since at least 2000. Defendants' conduct was and is in direct violation of Illinois law including, but not limited to, the Illinois Insurance Claims Fraud Prevention Act, including as codified at 740 ILCS 92/1 *et seq.* (West 2016).

8. At all times herein relevant Defendants engaged in the conduct herein alleged with actual knowledge, and the intent to present or allowing to be presented false or fraudulent claims for the payment of a loss or injury under a contract of insurance. Defendants prepared, made, subscribed to writings, or allowed such writings to be presented to insurance companies in support of false or fraudulent claims, knowing that the writings contained false, misleading and/or improperly fabricated representations. In doing so, Defendants engaged in conduct for financial gain.

9. 740 ILCS 92/5(b) provides that anyone who violates any provision of the Illinois Insurance Claims Fraud Prevention Act is liable for a civil penalty of no less than \$5,000, and up

to \$10,000, for each claim plus an assessment up to three times the amount of the damages sustained by the victim in addition to any other penalties that might be prescribed by law.

10. 740 ILCS 92/15(a) allows any interested person to bring a civil action for violation of the section for that person and the State of Illinois. Section 15(b) requires a copy of the Complaint and written disclosure of substantially all material evidence to be served on the State's Attorney and the Attorney General. The Complaint is also to be filed in camera and under seal for 60 days to allow the government to conduct its own investigation without the knowledge of Defendants, and to determine whether to join in this action.

11. Williams will comply with the requirements of 740 ILCS 92/15. Simultaneously with the filing of the original Complaint in this action, Williams will provide all material information regarding the allegations contained in this original Complaint to the State's Attorney's Office and to the Attorney General of the State of Illinois. Williams will offer complete cooperation in any potential investigation initiated by the one above-referenced government entities.

JURISDICTION AND VENUE

12. This is a civil action arising under the laws of the State of Illinois to redress violations of Illinois law including but not limited to Illinois Insurance Claims Fraud Prevention Act, codified as 740 ILCS 92/1 *et seq.* This Court has jurisdiction over the subject matter of this civil claim pursuant to 740 ILCS 92/1 *et seq.*

13. Jurisdiction over the person and venue are proper pursuant to 735 ILCS 5/2-209(b)(4) because Defendants are doing business within this State.

THE PARTIES

14. Relator BRIAN WILLIAMS is an individual residing in the State of Ohio. Williams was first employed by Safelite AutoGlass in 2001 at one of its Contact Centers but left in mid-2002. Williams returned to Safelite AutoGlass in 2013, and, between 2013 and 2020, would be promoted to his ultimate role at Safelite AutoGlass as product development and strategy manager. Mr. Williams earned multiple awards from Safelite AutoGlass for his role and contributions to the company, including bringing in millions of dollars in revenue. In 2020, his role at Safelite having been threatened due to the information he uncovered, Williams took the role of Strategic Products Procurement Manager with Belron, Safelite's parent company. Williams left Belron in December 2021. It was in his positions at Safelite AutoGlass and at Belron that Williams developed direct, and independent, knowledge of the facts set forth herein. Williams is thus the original source of the facts and information set forth in this Complaint concerning the activities of Defendants. The facts averred herein are based entirely upon his personal investigation, observation, and documents in his possession. Williams brings this action as Relator on behalf of and for the benefit of the People of the State of Illinois under the provisions of 740 ILCS 92/15.

15. Defendant SAFELITE GROUP, INC., formerly known as Belron US, is a corporation organized and existing under the laws of the State of Delaware with its principal place of business in Columbus, Ohio. Safelite Group oversees and manages two subsidiaries – Safelite AutoGlass and Safelite Solutions – which provide for auto glass repair and replacement, and insurance claims management. Safelite Group is a subsidiary of Belron, an English company headquartered in Egham, Surrey, United Kingdom.

16. Defendant SAFELITE FULFILLMENT, INC. is a corporation organized and existing under the laws of the State of Delaware with its principal place of business in Columbus,

Ohio. Defendant Safelite Fulfillment, Inc. is better known by, and operates under the trade name, Safelite AutoGlass. Safelite AutoGlass is the retail auto glass division of Safelite Group. Presenting itself as the largest auto glass repair and replacement organization in the United States, Safelite AutoGlass specializes in the repair and replacement of all types of vehicle glass damage.

17. Defendant SAFELITE SOLUTIONS LLC is a limited liability company organized and existing under the laws of the State of Delaware with its principal place of business in Columbus, Ohio. Defendant Safelite Solutions is the claims management operation division of Safelite Group. Safelite Solutions provides claims management solutions and serves as the third-party administrator of auto glass claims for more than 180 insurance and fleet companies. As third-party administrator, Safelite Solutions regularly investigates and prosecutes fraudulent claims on behalf of these insurance companies.

ALLEGATIONS

I. MOLDINGS AND ILLEGAL BILLING OF REPLACEMENT PARTS

18. Moldings (also spelled “mouldings”) are a rubber or plastic trim, most commonly black in color, that usually run along either the top or the top and sides of, and at times even around, the glass of a vehicle. Molding provides insulation and noise reduction while holding the window in place securely and safely. The molding around the glass allows the auto glass to do its job by shielding the vehicle passengers from wind, debris, rocks, and the like.

A. ORIGINAL EQUIPMENT MANUFACTURER AND AFTERMARKET MOLDING PARTS

19. When the glass of an automobile is damaged and is brought into a shop for repair or replacement, in addition to the glass that is replaced, the molding around the glass will also likely be replaced because the molding has or will likely become warped in the process of replacing the glass. Generally, there are two options available to the technician for replacing this part.

20. The first option is to use a molding from the original equipment manufacturer (“OEM”). OEM parts are parts made by the vehicle’s manufacturer. These parts are made to perfectly fit the specifications of the vehicle at issue. However, OEM parts are usually more expensive, precisely because they were made for and thus fit perfectly on the vehicle at issue.

21. The second option is to use an aftermarket molding. Aftermarket parts are parts that can be made either by a company other than the vehicle’s manufacturer or by the same factory that sold parts to the vehicle’s maker. Aftermarket parts are produced at a high volume, are generally cheaper, and tend to fit many different vehicles.

22. The selection of what type of part will be used for replacing that on the vehicle will depend on the vehicle’s insurance policy. Because OEM parts are generally more expensive than aftermarket parts, whether an insurance company will cover an OEM part in a claim will depend on the language in the policy and any laws that may be in effect. If the insurance policy will only cover for an aftermarket molding part and the holder of the policy decides to use an OEM molding part for a repair, the policyholder may opt to pay the difference between the cost of aftermarket and OEM parts.

B. SAFELITE’S SOLUTION FOR ITS INVENTORY PROBLEM

23. However, at Safelite AutoGlass, neither OEM nor aftermarket molding is being used in many cases to replace the window molding on a damaged vehicle. Instead, technicians have been using “universal” molding to replace the part specific molding on the vehicles brought in for repair.

24. Universal molding is generic, cheap rubber or plastic that may not be fit for the purpose of what it is being used for. Upon information and belief, Safelite purchased universal molding for approximately \$0.20/foot.

25. Even though they have access to vehicle-specific molding, Safelite technicians around the country can choose what molding they will ultimately use on a vehicle. And although OEM and aftermarket moldings are of better quality, technicians prefer using universal molding.

26. Technicians choose to use universal molding because it is easier and faster to use than an OEM or aftermarket molding. Furthermore, because Safelite AutoGlass lacks any specific processes and training for technicians, local technicians training other technicians likely teach them to use universal molding instead of part-specific molding.

27. Unless specifically authorized, however, insurance companies generally will not pay for universal moldings because they are not necessarily fit for the purpose that the OEM or aftermarket moldings are specifically manufactured for. Indeed, insurance policies require the use of either OEM or aftermarket parts for replacement purposes; universal moldings constitute neither.

28. Given Safelite's knowledge that its technicians use universal moldings instead of the part-specific moldings, but the insurance companies' requirement that replacement parts either be OEM or aftermarket parts, Safelite concocted a scheme to still get paid insurance rates regardless of the part selected by its technicians.

29. Specifically, Dino Lanno, then Vice President of Supply Chain, and Paul Groves, an Assistant Vice President for Inventory Management and Mr. Lanno's protégé, caused to be created and implemented programming to ensure that Safelite did not lose money when a technician swapped out parts.

30. In particular, Safelite's computer systems have been programmed to replace the name of the OEM or aftermarket part with universal molding (called "FLEXIMOLD" on Safelite's billing system) while keeping the part specific number and/or part specific price of the OEM or

aftermarket part intact. In Safelite's system, "FLEXIMOLD" does not have a rate because it does not exist.

31. At the back end, Safelite's billing system is programmed to remove any information concerning the universal molding and to invoice with the part specific name and National Auto Glass Specifications ("NAGS") information. The price carries through and is billed to the insurance company.

32. Thus, although Safelite's technicians are using generic universal molding to replace the molding on a vehicle instead of the part specific molding, Safelite Solutions systematically "upcodes," charging insurance companies the price of an OEM or aftermarket molding part.

33. Insurance companies do not know that they are being defrauded because Safelite intentionally programmed its billing systems to hide any information regarding the use of Fleximold. As a result, millions of claims have been paid out for these moldings at insurance rates, even though many of those claims were fraudulently billed to the insurance companies and others.

34. Furthermore, because Safelite Solutions is also the third-party administrator for the insurance companies, and itself regularly investigates and prosecutes claims of insurance fraud, insurance companies trust Safelite and would have no reason to believe that Safelite itself perpetuates insurance fraud. Indeed, while Safelite Solutions claims that it will prevent scams and fraud, Safelite Solutions has turned a blind eye and has otherwise maintained Safelite AutoGlass's fraudulent activities.

C. AUTOMOBILE PART REPLACEMENT AND BILLING WORKFLOW

35. Safelite's process of manipulating its billing systems to bill for an OEM or aftermarket part while using universal molding, demonstrates the lengths Safelite went to hide the issue from the insurance companies while, at the same time, obtaining a premium for its services.

36. When the glass of an automobile is damaged, and before or when the automobile is brought in for repair, information is gathered by Safelite AutoGlass to determine what repairs and/or replacements will be made to the vehicle.

37. Customer information is collected and received, and a job order is created. Safelite AutoGlass's computer systems will select the glass and corresponding molding(s) that are necessary to repair the damaged vehicle glass.

38. However, while the technician will usually use the system-selected glass, the molding used is frequently not be the system-ordered molding. Instead, technicians will use universal molding. As described in the following section, depending on the workflow, the change in the selection of the molding will either be (1) made automatically or (2) will be altered by the technician handling the job order.

1. "Auto Sub" Workflow

39. In the "Auto Sub" workflow, there is an automatic substitution of the computer-selected molding with universal molding.

40. Specifically, while the system will have selected the glass and corresponding molding(s), the part specific molding that was selected is automatically suppressed. In its place universal molding, named "FLEXIMOLD" in the system, is added.

41. The point of sales system automatically changes the part specific molding to FLEXIMOLD. However, *the part specific number and the pricing of the part that it replaced remain the same.*

42. The job order is then sent to the field and, if there are no issues with the order, the field associate will route the job, including sending the job to the warehouse to obtain the needed parts. Here, because the job requests "FLEXIMOLD," the molding taken from the warehouse – or

already at the location – will be universal molding instead of the part-specific molding. The parts and the job are then reviewed, and the job is then “checked out” for installation.

43. When the technician completes the install, the technician “checks in” the job for review. The store manager will verify that the paperwork matches the point of sales information. Once verified, the completed job is invoiced.

44. In the point of sales system, FLEXIMOLD shows as the part invoiced with the price of previous part carried over. However, the invoice that is generated by the system will only include the name of the original part-specific molding, based on the original part number that carried through the system and via the NAGS catalog.

45. The invoice is then sent to the payer – usually the insurance company – for payment.

2. “Tech Sub” Workflow

46. In the “Tech Sub” workflow, the technician will essentially replace the part-specific molding indicated by the system with universal molding.

47. The system will have selected the glass and corresponding molding(s), and the job order is sent to the field.

48. If there are no issues with the order, the field associate will route the job, including sending the job to the warehouse to obtain the needed parts. Here, the molding taken from the warehouse will be the part-specific molding. The parts and the job are reviewed, and the job is then “checked out” for installation.

49. However, the technician, instead of using the part specific molding brought from the warehouse, will use universal molding on the vehicle. In some cases,¹ the technician will

¹ In other cases, the technician uses universal molding, but never even bothers to change the part specific molding in the system. These specific instances cannot be verified other than through inspection of the vehicles. However, it is clear that this frequently occurs, as the amount of

replace the part specific molding in the system with FLEXIMOLD, using a specifically tailored “SUB with FLEX” radio button. However, *the point of sales system will keep the price of the part specific molding it replaced*. The part-specific molding will remain with the store or otherwise “travel” around various stores; in some cases, the molding is thrown away.

50. When the technician completes the install, the technician “checks in” the job for review. The store manager will verify that the paperwork matches the point of sales information. Once verified, the completed job is invoiced.

51. In the point of sales system, FLEXIMOLD shows as the part invoiced, but with the price of previous part carried over. However, the invoice that is generated by the system for transmittal to the payer will replace the name “FLEXIMOLD” with the name of the original part-specific molding once it finds the corresponding information based on part number and via the NAGS catalog.

52. The invoice is then sent to the payer – usually the insurance company – for payment.

3. Example of Charges

53. In Safelite’s billing system, FLEXIMOLD does not even have a rate. When the invoice is sent out for payment, the insurance company is charged at the rate set for the part-specific molding that the universal molding replaced.

a. Example 1: Invoice 229967

54. For instance, concerning invoice 229967, Safelite’s client, Safeco Insurance, was billed at \$157.05 to replace the windshield molding for a 2016 Toyota RAV 4. The part number billed to the client was 75533-0R010, an OEM molding for the vehicle. However, FLEXIMOLD was used instead of the OEM molding.

universal molding purchased by Safelite from manufacturers far outstrips the amount of FLEXIMOLD accounted for in the point-of-sale system.

55. The following figure is a screenshot from the NAGS/GlassMate system, showing the hardware parts that can be utilized for glass installation on a 2016 Toyota RAV 4.

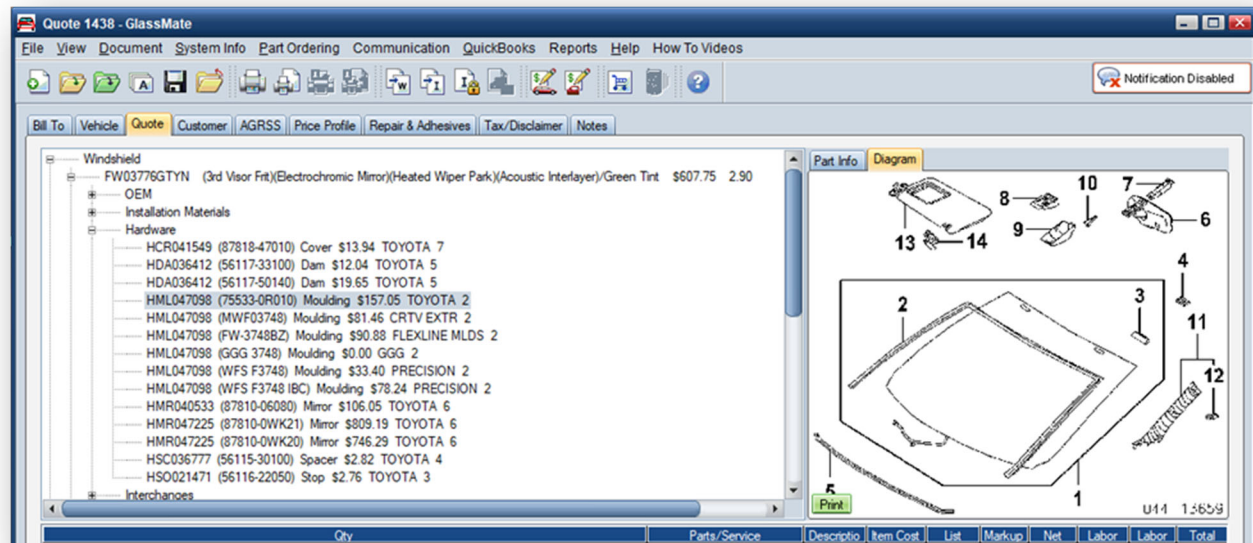

56. In the NAGS system pictured above, the molding is identified with the number “2” in the parts Diagram on the right side. The available molding varieties included on the parts list on the left are also identified with the number “2” at the end of each listing. For this vehicle, there are thus 6 molding options in the NAGS system, starting with the highlighted entry. The unique NAGS part number for each option is listed within the parenthesis, followed by the part type (“Moulding”), the list price, and the manufacturer. The highlighted entry—the Toyota OEM option—is the most expensive of the six options.

57. As can be seen in the foregoing figure, FLEXIMOLD is not an option in the NAGS database. There is no NAGS part number or list price for FLEXIMOLD, because FLEXIMOLD or universal molding is not an approved NAGS part for any specific vehicle or application. In other words, universal molding is generally considered not suitable for most vehicles given the abundance of vehicle-specific molding available on the market. In rare circumstances, for unique

vehicles, use of universal molding may be acceptable, but even then, would need to be billed based on the actual cost of the molding used, with supporting documentation.

58. The following figure is a screenshot from Safelite’s point of sale system for invoice 229967, showing that FLEXIMOLD was used, but was billed to the insurer, Safeco, at the price for the most expensive molding option, the OEM part, at a rate of \$157.05.

The screenshot displays the Safelite point of sale system interface. It is divided into several sections:

- Call Information:** Referral Number: 515180, Referral Date: 12/8/2019, Processed: Y, Created: 12/8/2019 10:44 PM, Created By: WEB, Request Type: CQ, Last Updated: 12/9/2019 12:31 PM, Last Updated By: 853, Referral Status: ORDER.
- Order Information:** Client Name: SAFECO INSURANCE - 408810 (INSURANCE), Customer Name: JAAMOUR, RAMI.
- Dispatch Number:** Y, **WO Sent Status:** Y, **Order Status:** ORDER.
- Claim Number:** 0415408750001, **Policy Number:** A3084276, **PO Number:**
- Fleet Unit Number:**, **Repair Deductible:** \$ 500.00, **Replace Deductible:** \$ 500.00.
- Price Difference Amount:** \$0.00, **Date Of Loss:** 12/7/2019, **Quote Parts Amount:** \$908.32.
- Quote Tax Amount:** \$90.84, **Quote Total Amount:** \$999.16, **Accept Cash Quote:** False.
- Collection Amount:** \$ 539.58, **Selected Quote Offer:**, **Type:** INS RETAIL.
- Reason Detail:**, **Provider Network:** Safelite.
- Work Order Information:** Work Order Number: 175633, CTU Number: 01804, Provider Number: 005045, Job Status/Sub-status: Invoiced, Service Type: I, Invoice Number: 229967.
- Order Summary:** 2016 TOYOTA RAV4 HYBRID 4 DOOR UTILITY, VIN #: JTMDJREV5GD025843. Includes a vehicle image.
- Parts List:** A table with columns: Glass / Part Type, Part #, SPS, Labor, Price. The row for 'MOULDING FLEXIMOLD' is circled in red, showing a price of \$157.05.
- Service Provider:** 005045 - SAFELITE AUTOGLASS - RENTON, WA. Provider Phone: Primary: (425) 228-4998. Provider Address: 765 RAINIER AVE S, RENTON, WA 98055.
- Comments to Provider:** Part requires recalibration.

59. The following figure is a screenshot from the back-end audit log of Safelite’s point of sale system for invoice 229967, showing that the Part Number field was changed from the OEM part number, 75533-0R010, to “FLEXIMOLD.” The price, however, remained the same as the NAGS list price for the OEM part number.

US/Shane Steele	12/9/2019 12:31:45 PM	UrethaneProductName		
US/Shane Steele	12/9/2019 12:31:45 PM	ApprovalReason		
US/Shane Steele	12/9/2019 12:31:45 PM	IsRemovable	True	
US/Shane Steele	12/9/2019 12:31:45 PM	PartPromoCode		
US/Shane Steele	12/9/2019 12:31:45 PM	UrethaneLotNumber		
US/Shane Steele	12/9/2019 12:31:45 PM	UrethaneBrandName		
US/Shane Steele	12/9/2019 12:31:45 PM	UrethaneProductName		
US/Shane Steele	12/9/2019 12:31:45 PM	ApprovalReason		
US/Shane Steele	12/9/2019 12:31:45 PM	IsRemovable	True	
US/Shane Steele	12/9/2019 12:31:45 PM	PartPromoCode		
US/Shane Steele	12/9/2019 12:31:45 PM	UrethaneLotNumber		
US/Shane Steele	12/9/2019 12:31:45 PM	PartNumber	75533-0R010	FLEXIMOLD
US/Shane Steele	12/9/2019 12:31:45 PM	UrethaneBrandName		
US/Shane Steele	12/9/2019 12:31:45 PM	UrethaneProductName		
US/Shane Steele	12/9/2019 12:31:45 PM	ApprovalReason		
US/Shane Steele	12/9/2019 12:31:45 PM	IsRemovable	True	
US/Shane Steele	12/9/2019 12:31:45 PM	PartPromoCode		
US/Shane Steele	12/9/2019 12:31:45 PM	ColorDifferenceCharge		0.00
US/Shane Steele	12/9/2019 12:31:45 PM	AgentAccountNumber		656024
US/Shane Steele	12/9/2019 12:31:45 PM	BusinessName		
US/Shane Steele	12/9/2019 12:31:45 PM	AddressLine3		
US/Shane Steele	12/9/2019 12:31:45 PM	IsRemovable		True
US/Shane Steele	12/9/2019 12:31:45 PM	IsRemovable		True
US/Shane Steele	12/9/2019 12:31:45 PM	IsRemovable		True
US/Shane Steele	12/9/2019 12:31:45 PM	IsRemovable		True
US/Shane Steele	12/9/2019 12:31:45 PM	IsRemovable		True

60. Finally, the figure below, a screengrab taken from Safelite’s billing system, shows that the “Part Used” was FLEXIMOLD, but the “Part Billed” was the part number for the OEM molding. The “Part Used” field is not shared with the insurance company.

```

00 PS                INVOICE INQUIRY SCREEN                PSC1010 08
                    ADDITIONAL PARTS                PSM1010  MAP4

INVOICE : 05045229967  TYPE: INVOICE  INSURED: JAAMOUR, RAMI
-----
PART USED: FLEXIMOLD          3/4
PART BILL: 75533-0R010      KIT: 2P:  NAGS HOURS: .0 INSTL FLAG: Y
INTERCHANGE: FLEXIMOLD      CNTL NO: 000000  RIB CODE: R  CAT CODE: 82  INV: N
PO: 000000  STORE  PCT      RIC  PCT      LIST STORE LIST HOST  NAGS  MLDG
PART $: 157.05  .0  157.05  .0  157.05  157.05  N
LABR $: .00  .00  .00  .00  .00  .00  1
KIT $: .00  .00  .00  .00  .00  .00  .00
-----
PART USED: LMESVCFULL-FEE  SELF SERVICE FULL LME
PART BILL: LABOR          KIT: 2P:  NAGS HOURS: .0 INSTL FLAG: N
INTERCHANGE: LABOR      CNTL NO: 0  RIB CODE: PF  CAT CODE: 75  INV: N
PO: 000000  STORE  PCT      RIC  PCT      LIST STORE LIST HOST  NAGS  MLDG
PART $: .00  .0  .00  .00  .00  .00  N
LABR $: 11.00  .00  .00  .00  .00  .00  1
KIT $: .00  .00  .00  .00  .00  .00  .00
-----
PF1  PF2  PF3  PF4  PF5  PF7  PF8
HELP RETURN END COMMENTS REPRINTS PG BWD PG FWD
MORE PART RECORDS EXIST

```

b. Example 2: Invoice 154185

61. In another example, for invoice 154185, Safelite’s client, Farmers Insurance, was billed at \$59.10 to replace the windshield molding for the 2019 Subaru Forester. The part number billed to the client was 65058SJ000, an OEM molding for the vehicle. However, universal molding – FLEXIMOLD – was used instead of the OEM molding.

62. The following figure is a screenshot from the NAGS/GlassMate system, showing the hardware parts that can be utilized for glass installation on a 2019 Subaru Forester.

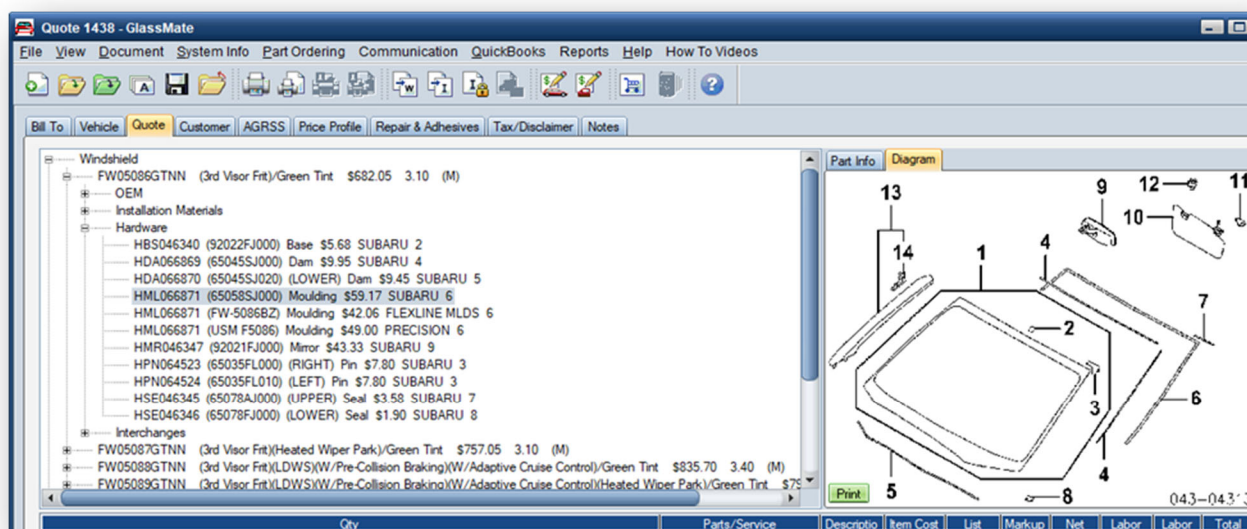

63. In the NAGS system pictured above, the molding is identified with the number “6” in the parts Diagram on the right side. The available molding varieties included on the parts list on the left are also identified with the number “6” at the end of each listing. For this vehicle, there are thus 3 molding options in the NAGS system, starting with the highlighted entry. The unique NAGS part number for each option is listed within the parenthesis, followed by the part type (“Moulding”), the list price, and the manufacturer. The highlighted entry—the Subaru OEM option—is the most expensive of the six options.

64. As can be seen in the foregoing figure, FLEXIMOLD is not an option in the NAGS database. There is no NAGS part number or list price for FLEXIMOLD, because FLEXIMOLD or universal molding is not an approved NAGS part for any specific vehicle or application. In other words, universal molding is generally considered not suitable for most vehicles given the abundance of vehicle-specific molding available on the market. In rare circumstances, for unique vehicles, use of universal molding may be acceptable, but even then, would need to be billed based on the actual cost of the molding used, with supporting documentation.

65. The following figure is a screenshot from Safelite's point of sale system for invoice 154185, showing that FLEXIMOLD was used, but was billed to the insurer, Farmers Insurance, at the price for the most expensive molding option, the OEM part, at a rate of \$59.10.

The screenshot displays the Safelite point of sale system interface. The 'Parts List' table is as follows:

Glass / Part Type	Part #	SPS Labor	Price
WINDSHIELD	FW05089GTNOEM N		\$910.76
ADAS RECALIBRATION	RECAL STATIC		\$250.00
MOULDING	FLEXIMOLD		\$59.10

The 'MOULDING FLEXIMOLD' row is circled in red. Other visible details include: Referral Number: 121201, Client Name: FARMERS INSURANCE - 200122 (INSURANCE), and Order Number: 154185.

66. The following figure is a screenshot from the back-end audit log of Safelite's point of sale system for invoice 154185, showing that the Part Number field was changed from the OEM

part number, 65058SJ000, to “FLEXIMOLD.” The price, however, remained the same as the NAGS list price for the OEM part number.

MrmJobCompleteProcessor	12/14/2019 11:33:36 AM	UrethaneProductName		2 SikaTack Safe30W
MrmJobCompleteProcessor	12/14/2019 11:33:36 AM	IsUpsell		False
MrmJobCompleteProcessor	12/14/2019 11:33:36 AM	UrethaneLotNumber		
MrmJobCompleteProcessor	12/14/2019 11:33:36 AM	DOTNumber		
MrmJobCompleteProcessor	12/14/2019 11:33:36 AM	IsUpsell		False
USChristopher.Quinn	12/14/2019 11:33:36 AM	PartNumber	65058SJ000	
MrmJobCompleteProcessor	12/14/2019 11:33:36 AM	PartNumber		FLEXIMOLD
USShanon.Gardner	12/14/2019 11:40:04 AM	Amount		1292.81
USShanon.Gardner	12/14/2019 11:40:04 AM	Type		Account
USShanon.Gardner	12/14/2019 11:40:04 AM	CardType		
USShanon.Gardner	12/14/2019 11:40:04 AM	InvoiceNumber		
USShanon.Gardner	12/14/2019 11:40:05 AM	DiscountAmountReason		

67. Finally, the figure below, a screengrab taken from Safelite’s billing system, shows that the “Part Used” was FLEXIMOLD, but the “Part Billed” was the part number for the OEM molding. The “Part Used” field is not shared with the insurance company.

```

00 PS                               INVOICE INQUIRY SCREEN                               PSC1010 08
                                ADDITIONAL PARTS                               PSM1010  MAP4

INVOICE : 5153154185             TYPE: INVOICE             INSURED: WASSENAAR, LAURA
-----
PART USED: FLEXIMOLD             WINDSHIELD~3/4
PART BILL: 65058SJ000           KIT: 2P:                 NAGS HOURS: .0 INSTL FLAG: Y
INTERCHANGE: FLEXIMOLD         CNTL NO: 000000         RIB CODE: R  CAT CODE: 82  INV: N
PO: 000000   STORE   PCT       RIC   PCT       LIST STORE LIST HOST NAGS MLDG
PART $:      59.10   .0        59.10   .0        59.10       59.10    N
LABR $:       .00           .00           QTY:       1
KIT $:       .00           .00           COST:      .00
-----
PART USED: PF-RPL-FARMERS       PROCESSING FEE-RPL FARMER
PART BILL: LABOR                KIT: 2P:                 NAGS HOURS: .0 INSTL FLAG: N
INTERCHANGE: LABOR             CNTL NO: 0              RIB CODE: PF CAT CODE: 75  INV: N
PO: 000000   STORE   PCT       RIC   PCT       LIST STORE LIST HOST NAGS MLDG
PART $:       .00   .0        .00           .00           .00    N
LABR $:      10.55           .00           QTY:       1
KIT $:       .00           .00           COST:      .00
-----
PF1  PF2  PF3  PF4  PF5  PF7  PF8
HELP RETURN END COMMENTS REPRINTS PG BWD PG FWD

```

c. Example 3: Invoice 568839

68. For invoice 568839, Safelite's client, State Farm Insurance, was billed at \$29.06 to replace the windshield molding for the 2000 Toyota Tundra. The part number billed to the client was MWF2108, an aftermarket part-specific molding for the vehicle. However, universal molding – FLEXIMOLD – was used instead of the aftermarket part-specific molding.

69. The following figure is a screenshot from the NAGS/GlassMate system, showing the hardware parts that can be utilized for glass installation on a 2000 Toyota Tundra.

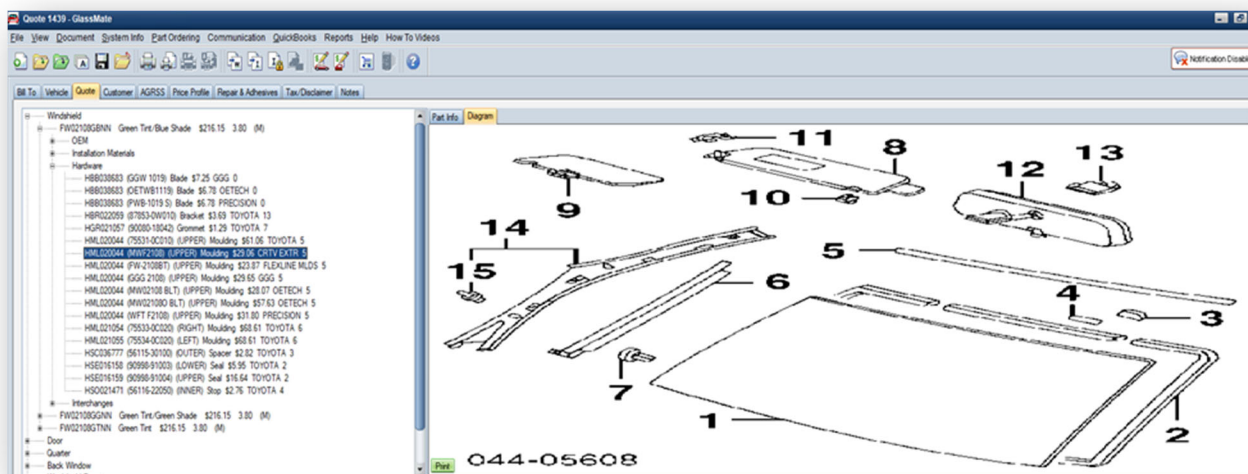

70. In the NAGS database pictured above, the upper molding is identified with the number “5” in the parts Diagram on the right side. The available molding varieties included on the parts list on the left are also identified with the number “5” at the end of each listing. For this vehicle, there are thus 7 upper molding options in the NAGS system. The unique NAGS part number for each option is listed within the parenthesis, followed by the part type (“(UPPER Moulding)”), the list price, and the manufacturer.

71. As can be seen in the foregoing figure, FLEXIMOLD is not an option in the NAGS database. There is no NAGS part number or list price for FLEXIMOLD, because FLEXIMOLD

or universal molding is not an approved NAGS part for any specific vehicle or application. In other words, universal molding is generally considered not suitable for most vehicles given the abundance of vehicle-specific molding available on the market. In rare circumstances, for unique vehicles, use of universal molding may be acceptable, but even then, would need to be billed based on the actual cost of the molding used, with supporting documentation.

72. The following figure is a screenshot from Safelite's point of sale system for invoice 568839, showing that FLEXIMOLD was used, but was billed to the insurer, State Farm Insurance, at the price for the aftermarket part, at a rate of \$29.06.

The screenshot displays the Safelite point of sale system interface for invoice 568839. The interface is divided into several sections:

- Call Information:** Referral Number: 146583645, Referral Date: 12/3/2019, Processed: Y, Created: 12/3/2019 5:29 PM, Created By: XSS, Request Type: CQ scripling options, Last Updated: 1/28/2020 11:31 AM, Last Updated By: 121, Referral Status: ORDER.
- Order Information:** Client Name: STATE FARM INSURANCE - 800002 (INSURANCE), Customer Name: MORGAN, MICHAEL.
- Order Summary:** 2000 TOYOTA TUNDRA PICKUP 2 DOOR EXTENDED CAB, VIN #: 5TBRT3413YS054932. Includes a vehicle diagram.
- Parts List:** A table with columns: Glass / Part Type, Part #, SPS, Labor, Price. The entry 'MOULDING FLEXIMOLD' is circled in red, with a price of \$29.06. The entry above it, 'WINDSHIELD FW02108GNN R', has a price of \$304.76.
- Service Provider:** 001826 - SAFELITE AUTOGLASS - NEW ORLEANS, LA SOR-CTU, Service Center ID: 050054, Provider Phone: Primary: (504) 456-2003, Provider Address: 901 LABARRE RD, METAIRIE, LA 70001.
- Work Order Information:** Work Order Number: 302628, CTU Number: 01826, Provider Number: 001826, Job Status/Sub-status: Invoiced, Service Type: I, Invoice Number: 568839.

73. The following figure is a screenshot from the back-end audit log of Safelite's point of sale system for invoice 568839, showing that the Part Number field was changed from the aftermarket part number, MWF2108, to "FLEXIMOLD." The price, however, remained the same as the NAGS list price for the aftermarket part number.

Audit Log				
Last Upd By	Last Upd	Data Field	Original Value	New Value
USAdelina.Torrez	12/3/2019 5:39:00 PM	PartNumber		FW02108 GGN
USAdelina.Torrez	12/3/2019 5:39:00 PM	PartNumber		MWF2108
USAdelina.Torrez	12/3/2019 5:39:00 PM	PartNumber	MWF2108	FLEXIMOLD
USAdelina.Torrez	12/3/2019 5:39:00 PM	PartCode	M	F
USAdelina.Torrez	12/3/2019 5:39:00 PM	CollectionAmount		0.00
USAdelina.Torrez	12/3/2019 5:39:00 PM	SubStatus	NOSUBSTATUS	NoSubStatus
USAdelina.Torrez	12/3/2019 5:39:00 PM	TechnicianID		UNROUTED
USAdelina.Torrez	12/3/2019 5:39:00 PM	DateScheduled		12/3/2019 5:38:59 PM
USAdelina.Torrez	12/3/2019 5:39:00 PM	ParentAccountType	0	16
USAdelina.Torrez	12/3/2019 5:39:00 PM	IsSabrixTaxed	False	True
USAdelina.Torrez	12/3/2019 5:39:00 PM	WasScheduled	False	True

74. Finally, the figure below, a screengrab taken from Safelite's billing system, shows that the "Part Used" was FLEXIMOLD, but the "Part Billed" was the part number for the aftermarket molding. The "Part Used" field is not shared with the insurance company.

```

00 PS                INVOICE INQUIRY SCREEN                PSC1010 08
                    ADDITIONAL PARTS                    PSM1010  MAP4

INVOICE : 1826568839  TYPE: INVOICE    INSURED: MORGAN, MICHAEL
-----
PART USED: FW02108 GGN      SOLAR
PART BILL: FW02108 GGN      KIT: T2 2P:    NAGS HOURS: 3.8 INSTL FLAG: Y
INTERCHANGE: FW02108 GGN  CNTL NO: 838607  RIB CODE: D  CAT CODE: 21  INV: Y
PO: 137020  STORE  PCT      RIC  PCT      LIST STORE LIST HOST NAGS MLDG
PART $:    133.55  38.0    133.55  38.0    215.40    216.15    Y
LABR $:    148.20          148.20          QTY:      1
KIT $:     20.00          20.00          COST:     32.43
-----
PART USED: FLEXIMOLD      UPPER
PART BILL: MWF2108        KIT: 2P:    NAGS HOURS: .0 INSTL FLAG: Y
INTERCHANGE: FLEXIMOLD    CNTL NO: 000000  RIB CODE: R  CAT CODE: 82  INV: N
PO: 000000  STORE  PCT      RIC  PCT      LIST STORE LIST HOST NAGS MLDG
PART $:     29.06   .0    29.06   .0    29.06    29.06    N
LABR $:     .00          .00          QTY:      1
KIT $:     .00          .00          COST:     .00
-----
PF1  PF2  PF3  PF4  PF5  PF7  PF8
HELP RETURN END  COMMENTS REPRINTS PG BWD PG FWD

```

75. In each of the above cases, universal molding automatically replaced the part-specific molding. However, the part number and the price for the original part remained the same and was carried through for invoicing and payment. Similarly, in cases where the technician

replaced the part-specific molding with universal molding, the price of part-specific molding is invoiced to the client.

76. For the years 2015 through 2020, Safelite engaged in this practice of using universal molding but charged insurance companies and others for part-specific molding on over 1 million vehicles. In 2019 and 2020 alone, Safelite charged insurance companies and others for part-specific molding, but used universal molding to outfit the vehicles, for over 255,000 vehicles, over 4,850 of which were for vehicles whose glass was replaced in Illinois alone.

77. For the vast majority of insurance companies that Safelite did business with, the amount Safelite charged was the amount it was paid. In other words, when Safelite charged for part-specific molding despite using universal molding, it was paid the part-specific molding list price from NAGS. With GEICO – Safelite’s largest client – it had a contractual agreement up until 2020 that gave GEICO a substantial discount on parts. However, Safelite’s agreement with GEICO is no longer in effect, and, as such, GEICO is also being charged the full amount of the part-specific molding.

78. Safelite continued to engage in the same practice in 2021, using universal molding instead of part-specific molding on numerous vehicles in Illinois. And, upon information and belief, Safelite continues to charge for part-specific molding, although its technicians use universal molding in place of the part-specific molding.

D. HOW SAFELITE’S FRAUDULENT ACTIONS CAME TO LIGHT

79. In the summer of 2019, as part of his job as product development and strategy manager, Relator was reviewing the purchases and sales of products at Safelite AutoGlass when he noticed discrepancies between molding purchases, usage, and sales. Specifically, Relator noticed that Safelite AutoGlass was only billing universal molding for approximately half of what

was being purchased by Safelite AutoGlass. Similarly, Relator noticed that while there were sales for a number of other moldings, Safelite AutoGlass's purchases for those same moldings were for less than what was sold.

80. Relator pulled whatever data he was able to find and spoke with some technicians about his concerns. Relator found out that the technicians were free to use whatever molding they wanted, and, in many cases, they did use universal molding instead of the part-specific molding for the vehicle. But the point of sales system would charge the universal molding at the same amount for the part the technician substituted.

81. Between August and September 2019, Relator investigated the situation by accessing audit logs in the point of sales system and information from Safelite's backend mainframe. In reviewing information from the mainframe, Relator found out that while a technician would use FLEXIMOLD as the part, the part billed would be the dealer part that was removed from the work order and not installed on the vehicle. Safelite's mainframe developer, Randy McCombs, stated that it had been happening this way for as long as he had been with the company, which was, at the time, for over 20 years.

82. In late September 2019-early October 2019, Relator met with various company executives to discuss his findings, including Steve Miggo, the Chief Operating Officer of Safelite AutoGlass and Relator's direct manager. Mr. Miggo agreed that it was important to get to the bottom of this issue before raising any alarms. Relator was instructed to continue investigating the issue, which at that point also involved David Cook, a finance director assigned to Relator as part of the Supply Chain Department, to mine Safelite's data.

83. From a review of the data put together by Mr. Cook, Relator found out that Safelite AutoGlass was systematically billing for OEM or aftermarket parts when universal moldings were

actually used in their place. Furthermore, the data showed that this sort of billing was happening across all insurance clients and customers billed via account, including government agencies, commercial accounts, and fleet accounts.

84. In November 2019, Relator sought billing information from Precilla Jackson, an analyst at Safelite Solutions. Ms. Jackson created a program that allowed her to pull and compile a report of 2019 year-to-date parts that were used versus the parts that were billed for all moldings. Ms. Jackson's information confirmed that numerous insurance invoices were sent out that billed the original pricing for moldings, but where technicians actually used universal molding. Ms. Jackson caused to set up a script in Safelite's internal system that allowed Relator to create similar reports, which Relator used to compile reports for 2015-2018 and 2020.

85. Having confirmed his suspicions, Relator then went over his findings with Mr. Miggo, who seemed concerned and indicated that it was "disturbing" that this was happening. Mr. Miggo asked Relator to "stop digging" until the "appropriate" people were contacted. Relator asked, and Mr. Miggo agreed, that he should speak with Jon Cardi, the then Senior Vice President, Strategic Client Sales and Support, at Safelite Solutions, for guidance.

86. In late November-early December 2019, Relator met with Mr. Cardi and relayed to him his findings. Mr. Cardi became visibly upset upon hearing Relator's research to date. Mr. Cardi agreed that the next steps were for Relator to finish his investigation and, thereafter, to meet with a larger group to review his findings, assess the risk, and decide how to fix the issue. Although he appeared interested in fixing the problem going forward, Mr. Cardi expressly indicated that the company would not provide any compensation for their years of overbilling, stating "we aren't going to go backwards."

87. Relator met with Mr. Miggo to debrief his meeting with Mr. Cardi. Mr. Miggo asked Relator to finish his report and to schedule the larger meeting to discuss the problem. Mr. Miggo also indicated that he would update Renee Cacchillo. Ms. Cacchillo was, at the time, the Chief Customer Experience Officer for Safelite. Ms. Cacchillo is currently Safelite's President and CEO.

88. After further meetings through January 2020, Relator was tasked with attempting to fix the overbilling scheme.

89. Also in January 2020, Relator spoke with Mr. Miggo, who indicated his surprise "at how cavalier [Safelite] Solutions is about the issue." Relator also spoke with Tim Spencer, who was then Chief Financial Officer of Safelite AutoGlass. Mr. Spencer pointed out that something similar had happened in the United Kingdom and, after an insurance company found out what had happened, the UK team stopped engaging in this practice.²

90. On January 23, 2020, Relator reached out to the Safelite Solutions's billing team to obtain more information on how the universal moldings were being billed so that he could use that information to try to fix the problem. In an email conversation with Denise Shoopman, the billing manager at Safelite Solutions, Relator found out that when Safelite used universal molding for vehicles insured by State Farm Insurance,³ "[w]e do not bill FLEXIMOLD to Lynx Quest Commerce [State Farm's Third-Party Administrator] as they require POPs [proof of purchases]. Many times, I believe we just select another less expensive molding that we know we can get paid

² Unlike in the UK, where the billing is made directly to the insurance company, here, Safelite Solutions serves as the third-party administrator and intermediary between Safelite AutoGlass and the insurance company. And since Safelite Solutions is the intermediary and bills the insurance companies itself, and is further the investigator of insurance fraud, insurance companies would have no reason to believe that Safelite was itself committing fraud.

³ Unlike some 85% of insurance companies which use Safelite Solutions as its third-party administrator, State Farm Insurance – the largest insurer of vehicles – uses the services of Lynx Quest Commerce as its third-party administrator.

on.” Upon receiving that email, Relator spoke with Ms. Shoopman, who told him that a “former executive” had instructed them to bill for the original part. Relator further found out that this billing practice had been happening for years.

91. Between the end of January 2020 and March 2020, Relator engaged Safelite’s IT department to try to find a fix for billing moldings. The team was able to come up with a partial solution that would block dealer parts from being billed incorrectly, but it would also prevent any billing for those parts (i.e., in the rare cases where the dealer parts were actually used, they could not be billed). This solution only fixed approximately 5% of the issue but dealt with the highest dollar amounts. Relator reported this back to the group and included in his report that he would continue working on a longer-term solution. No one in the group objected.

92. Upon information and belief, Po-Wen Shi, a member of Safelite’s IT department who was involved in helping Relator with the fix, was also relaying information and updates to Ms. Cacchillo concerning this fix.

93. In March 2020, in an attempt to silence him and stop his work attempting to fix the scheme, Relator was furloughed by Safelite for four months without pay or a specified return date. The reason given by Safelite for Relator’s furlough was COVID. Relator found out that he was the only management person in the supply chain to be furloughed. Relator was not provided a salary during the period in which he was furloughed.

94. In May 2020, Relator was informed by a colleague at Safelite that he was to be terminated. However, Relator was ultimately not fired; instead, he was contacted in late June 2020 by Mr. Miggo, who informed him that Relator would be returning in July 2020 and would be reporting to Mr. Lanno instead of Mr. Miggo.

95. Prior to Relator's return, Mr. Lanno contacted Relator to inform him that his job duties would be changing, even though Relator's work had helped Safelite bring in millions of dollars in revenue. Upon Relator's request for more information, Mr. Lanno was unable to provide anything further.

96. When Relator returned to work in July 2020, Relator spoke with Mr. Lanno to discuss Relator's open projects, including the project to fix the billing issue. That was when Mr. Lanno informed Relator that he and Mr. Groves had "put that in place years ago and it is fine as it is." Mr. Lanno further informed Relator that the programming was implemented to help with inventory and to ensure that Safelite did not lose money when a technician swapped out parts. When Relator indicated that he should talk to Mr. Miggo about what he had just learned, Mr. Lanno threatened Relator, indicating that his career would "end up in the ditch."

97. Relator spoke with Mr. Miggo the next day about Mr. Lanno's plans and asked whether Mr. Miggo still wanted Relator to fix the universal molding billing issues. Relator did not inform Mr. Miggo that Mr. Lanno had created the issue in the first instance or that he had threatened Relator's job. Mr. Miggo indicated that Relator should continue working on a fix and speak again with Mr. Lanno about fixing this issue.

98. Relator again reached out to Mr. Lanno to try to discuss Relator's projects as well as the billing issue. Mr. Lanno became agitated and rambled on about the fact that the "FBI" would get involved and that it would only become a huge problem for Safelite.

99. On July 15, 2020, Mr. Lanno emailed Relator, stating that he had met with Mr. Miggo, Mr. Spencer, and Mr. Cardi, and that they had decided that the FLEXIMOLD billing project was not a priority, and that Relator should stop working on it. Mr. Lanno also asked Relator to send a note to everyone involved that Relator was going to stop working on the project. Relator

responded with concern and refused to send the note. Relator indicated that Mr. Lanno could send the note in his stead.

100. Relator met with Mr. Miggo in person about the email that Mr. Lanno sent. Mr. Miggo responded that Mr. Lanno did not reach out to him and that he did not know what Mr. Lanno was talking about. Nonetheless, Mr. Miggo noted that the problem still needed to be fixed.

101. On or about August 20, 2020, Mr. Lanno discussed with Relator his future with Safelite. Mr. Lanno gave Relator two options. Relator could work on a team that he did not have a good relationship with and for an individual who was at the same management level as Relator. The other option was for Relator to apply for a role with Belron. Because Relator had three young children at home, and because the first option was essentially a demotion, Relator chose to pursue the job with Belron.

102. Relator again met with Mr. Miggo to discuss his transition and to review the FLEXIMOLD billing project. Mr. Miggo agreed that Relator should continue working on it, and Relator agreed to finish the project. Relator's new manager at Belron, Rolando Herrera, agreed and allowed Relator to continue working on the issue.

103. Between October 2020 and April 2021, multiple meetings were held with the Safelite supply chain team and a few others to discuss a long-term fix. Many of the people who were on the team were Mr. Lanno's subordinates. Thus, as more people were added, the project became difficult to manage as the team brought up roadblock after roadblock. Even though Relator was now Strategic Products Procurement Manager with Belron, Safelite's parent company, Relator was unable to cause any changes to the billing practice.

104. On or about April 22, 2021, Relator escalated the matter to Tom Feeney, the then CEO of Safelite. Relator met with Mr. Feeney multiple times that day. The first time Relator met

with Mr. Feeney individually to inform him about Relator's findings. Later that day, Relator met with Mr. Feeney and Mr. Spencer to discuss the issue. Mr. Spencer had thought that the issue had been resolved, but Mr. Spencer agreed that the billing issue needed to be fixed as soon as possible. Mr. Spencer committed to putting a team of executives together to fix the issue, and that Kathy Paskvan, a Safelite Vice President and its Controller, would lead the group.

105. The next day, on or about April 23, 2021, Relator met with Ms. Paskvan as well as with Dan Loyal, Vice President of Operations, Chad Flowers, Vice President of Operations, Roxanne Wilson, Senior Vice President of Risk, and Ben Naylor, Vice President of Information Technology, to bring everyone up to speed and to give Relator an opportunity to review the issue and to provide a potential long-term fix to the problem.

106. The group worked on the issue through June 30, 2021. But there was no mention of notifying past customers or paying anything back to the customers, and Relator continued to encounter roadblocks. Thus, Relator brought his concerns to Belron management. Belron management initiated an internal investigation of Safelite's billing practices.

E. SAFELITE'S ALLEGED INTERNAL INVESTIGATION AND AFTERMATH

107. At the end of November 2021, Relator was contacted by Johnny Vorce, the Global Head of Risk Management for Belron. Relator was asked to fly to Orlando on short notice for a meeting about the investigation. The meeting included Belron's outside counsel.

108. Shortly following that meeting, as it became clear to Relator that after two years of attempts to bring attention and solutions to the problem, Defendants had little interest in actually stopping the schemes, Relator resigned from Belron on or about December 10, 2021.

109. Upon information and belief, Safelite continues to bill insurance companies for parts that it did not actually use on the vehicle.

II. SAFELITE'S CARE AND CLEAN SERVICE

110. As part of its response to the COVID-19 pandemic, Safelite implemented a Care and Clean service ("ECTC Service") in or about April 2020.

111. The ECTC Service provided that Safelite AutoGlass's technicians would utilize special sanitation wipes to clean the vehicle before beginning a job and cleaning the vehicle prior to returning the vehicle to its owner.

112. Although Safelite could not sell the service to customers who self-paid, Safelite was able to sell the ECTC Service to the insurance companies as an additional service for a fee. Upon information and belief, insurance companies were charged approximately \$30 for the service.

113. According to internal Safelite documents, the ECTC service required the use of at least four disinfecting wipes on each vehicle: "[t]wo wipes should be used when beginning a job, and two wipes once the job has been completed." the company data, however, shows that wipes were not being used.

114. Specifically, in a Microsoft Excel spreadsheet that covered the last four months of 2020, Safelite noted that while there should have been a need for 7,996,980 wipes throughout the United States, only 2,240,910 were sent, i.e., "the amount of product billed out from warehouses to their retail locations." In Illinois, while there should have been a need for 133,468 wipes, only 54,960 were billed out from warehouses.

115. Even though Safelite's technicians did not sanitize the vehicles either before or after a job for a majority of the vehicles at issue, Safelite nonetheless billed insurance companies for the ECTC Service.

116. Upon information and belief, Safelite ended the ECTC Service in or around May 2021, having charged for this service on approximately 2.5 million insurance-related jobs. In turn, the service generated approximately \$70 million in revenue for Safelite. However, Safelite never reimbursed the insurance companies where the service never happened.

117. At the same time, upon information and belief, Safelite blocked other companies that provide glass replacement services from obtaining reimbursement for similar sanitation services.

FIRST CLAIM FOR RELIEF

(Illinois Insurance Claims Fraud Prevention Act – 740 ILCS 92/5 Alleged Against Defendants by the State of Illinois *ex rel.* Williams)

118. Williams re-alleges and incorporates herein by reference each and every allegation contained in the proceeding paragraphs as though set forth in full herein.

119. This is a claim for penalties and assessments under the Illinois Insurance Claims Fraud Prevention Act, 740 ILCS 92/1 *et seq.*

120. By virtue of the conduct alleged herein, Defendants, and each of them, have repeatedly violated 740 ILCS 92/5 by engaging in the following prohibited acts or conduct:

A. Knowingly presenting or causing to be presented false or fraudulent claims for the payment of a loss of injury under a contract of insurance; and/or

B. Knowingly making or causing to be made false or fraudulent claims for payment of a benefit; and/or

C. Presenting or causing to be presented written or oral statements as part of, or in support of claims for payment or other benefit pursuant to an insurance policy, knowing that the statement contains false or misleading information concerning material facts; and/or

D. Preparing or making any written or oral statements that are intended to be presented to an insurer in connection with, or in support of, claims or benefit pursuant to an insurance policy, knowing that the statements contain false or misleading information concerning material facts.

121. As a result of such conduct on the part of Defendants, insurance companies and consumers have been damaged in substantial amounts, and are entitled to penalties and assessments for each violation of 740 ILCS 92/5, to be determined at trial.

122. Further, injunctive relief, including a preliminary injunction, is warranted to prohibit Defendants from engaging in conduct that violates 740 ILCS 92/5.

PRAYER FOR RELIEF

WHEREFORE, Relator prays for judgment against Defendants, in an amount to be proven at trial, as follows:

1. For civil penalties of \$10,000 be impose for each and every fraudulent claim Defendants presented or caused to be presented to an insurance company or a consumer;
2. For damages sufficient to disgorge its unlawful profit and provide restitution for its fraudulent conduct;
3. For treble damages;
4. For pre- and post-judgment interest, along with attorney's fees, costs, and expenses necessarily incurred in bringing and pressing this case;
5. For an injunction prohibiting Defendants from violating 740 ILCS 92/5;
6. For Relator to be awarded the maximum percentage of any recovery allowed to him; and
7. For such other further relief as the Court may deem just and proper.

DEMAND FOR JURY TRIAL

Relator hereby demands trial by jury as to all issues so triable.

Dated: January 19, 2023

BRIAN WILLIAMS, PLAINTIFF-RELATOR



By _____
One of His Attorneys

DAVID J. CHIZEWER
david.chizewer@goldbergkohn.com
ROGER A. LEWIS
roger.lewis@goldbergkohn.com
GOLDBERG KOHN LTD.
55 E. Monroe Street, Suite 3300
Chicago, Illinois 60603
Telephone: (312) 201-4000
Facsimile: (312) 332-2196
Firm I.D. 46703

ANDREW S. MACKAY (*pro hac vice* to be filed)
amackay@donahue.com
MARIO M. CHOI (*pro hac vice* to be filed)
mchoi@donahue.com
DONAHUE FITZGERALD LLP
Attorneys at Law
1999 Harrison Street, 26th Floor
Oakland, California 94612-3520
Telephone: (510) 451-3300
Facsimile: (510) 451-1527

MARK C. MOLUMPY (*pro hac vice* to be filed)
mmolumphy@cpmlegal.com
JUSTIN T. BERGER (*pro hac vice* to be filed)
jberger@cpmlegal.com
COTCHETT, PITRE & McCARTHY, LLP
San Francisco Airport Office Center
840 Malcolm Road
Burlingame, CA 94010
Telephone: (650) 697-6000
Facsimile: (650) 697-0577

Attorneys for Plaintiff-Relator
BRIAN WILLIAMS